

TORNADO AC-1 DRY-MIX SHOTCRETE MACHINE

Solutions for mining, tunnelling, building, reconstruction,
slope protection and refractory application

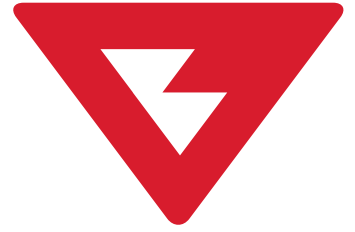

TORNADO
shotcrete equipment



Shotcreting— is the construction technique, where concrete pneumatically conveyed through a hose and projected layer by layer at high velocity onto a surface



Dry mix shotcrete (gunitite) is a versatile, flexible and economical method of construction and reconstruction. Properly chosen equipment allows to achieve good results in sprayed concrete application. TORNADO offers equipment, effective for the following types of work:

APPLICATION

- repair of concrete and reinforced concrete structures
- construction of tanks and containers
- slope protection in tunneling and mining construction
- application of refractory materials in metallurgy, chemical, glass, cement and other industries associated with high-temperature processes
- soil stabilisation (pits and storage facilities, strengthening of the slopes at the construction of interchanges, bridges and so on.)
- conveying of loose materials (sand, gravel, etc.).
- as a sandblasting equipment
- sprayable membranes application
- house building incl. EVG 3d panel

METHOD ADVANTAGES

The advantages of dry shotcrete method lead to its versatility. Dry shotcrete is a traditional world-known method of applying sprayed concrete and characterized by:

- improved characteristics of mechanical strength, higher concrete density, better frost-resistance and water resistance
- high initial strength of the sprayed concrete layer
- high level of adhesion to different surfaces
- possibility of conveying mixtures to long distances (up to 400 m.)
- ability to work in the "start-stop" mode
- pre-mixing is not necessary
- easy equipment cleaning
- rare hose blockage
- the independence from concrete suppliers (the possibility of preparing dry mix on building site)

Working principle

Dry mix (aggregates, additives, astringent e.g. cement) is loaded into a hopper, where it falls into the rotary dosing drum. Then followed by compressed air, dry mix is fed into the spraying nozzle. In the nozzle, the material is mixed with the water or with an aqueous solution of additives and entrains on the surface by the compressed air. Upon impact with the surface, significant concrete consolidation is achieved

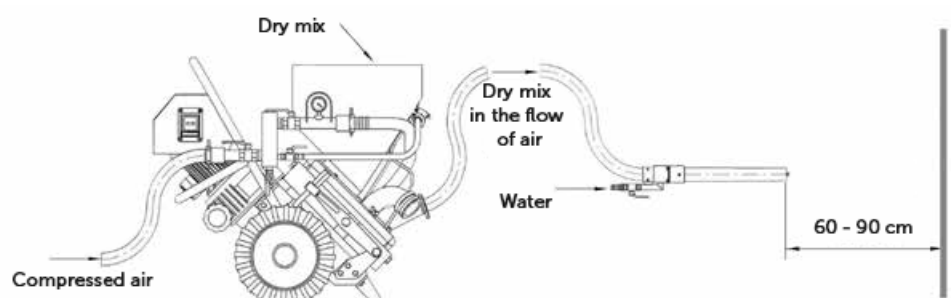

Overview

TORNADO AC-1 dry shotcrete machine is based on widespread rotary principle and furthermore simplified due to one-sided dosing drum design, which allows significantly reduce size and weight of machine. Robust design and reliable hardware assure market's lowest maintaining costs and easiest handling. Versatility of AC-1 allows to adapt the usage for most types of dry shotcrete works. AC-1 machines used for more than 15 years at numerous building sites in the former USSR and European countries, and in that time have proven their reliability and maintainability in harsh environment.

Features and benefits



Mobility and compactness.
Pneumatic large-diameter wheels ensure easy movement and transportation. Small size allows the closest to application site stationing. The machine can easily be moved by one person.



Simple and robust design with installed world's leading drive gears (production of Italy and Germany) provides the long-term operation life



Variable speed geared motor allows to change the output of the machine smoothly in full range, and instantly adapt the machine to the building site needs



Operating costs decreased by 30% due to the design with only one sealing plate. **Refacing of sealing plate** can significantly reduce the operating costs. Assembly and disassembly of the machine can be done in seconds. **Fast cleaning** and easy access to wear parts minimize downtime



Capacious feeding hopper located at a height of less than 1 m. and simplifies filling machine both manually and mechanically. Simple and reliable mechanism of the pneumatic vibrator provides the necessary force to mixture passage

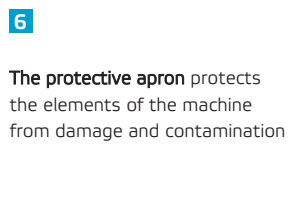

The protective apron protects the elements of the machine from damage and contamination

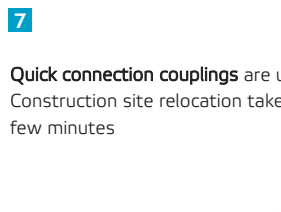

Quick connection couplings are used. Construction site relocation takes a few minutes

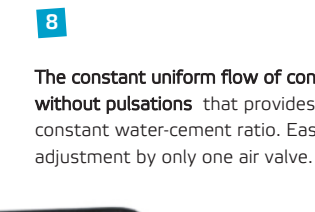

The constant uniform flow of concrete without pulsations that provides a constant water-cement ratio. Easy adjustment by only one air valve.



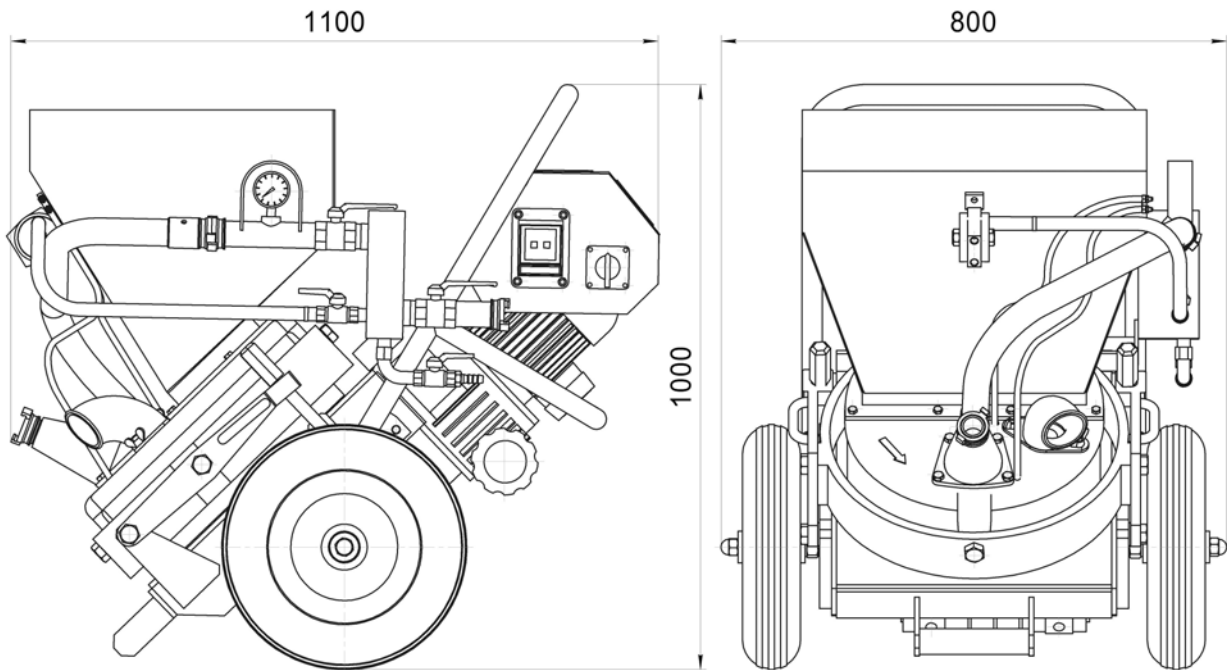

AC-1 DRY-MIX SHOTCRETE MACHINE

Technical data	unit	electric drive	explosion proof model	
			electric motor	air motor
Working temperature	°C	up +5°C to +50°C		
Dosing rotor volume	dm ³	3/4		
Bunker volume	dm ³	85		
Theoretical output*	m ³ /hour	0,5 - 3,6	0,5 - 3,6	0,5 - 3,6
Dosing rotor rotation speed	min-1	3 - 15	3 - 15	3-15
Air compressor pressure	mPa	0,5		
Air consumption total	m ³ /min	3,5 - 6,0		6,5 - 9,0
Air consumption for pneumatic vibrator	m ³ /min	0,5 - 0,7		
Drive power	kW	2,2		3,2 - 3,6
Drive type		3 x 380B 50 Hz	3x380/660B 50 Hz	air motor
Transport distance horizontally, dry method	m	to 200		
Transport distance vertically, dry method	m	to 100		

Machine dimensions

	mm	1100	1100	1100
Length	mm	1100	1100	1100
Width	mm	800	800	800
Height	mm	1000	1000	1000
Weight with no accessories	kg	284	310	310

Recommended assembly:

- AC-1 dry shotcrete machine (incl. feeding hopper, sieve, vibrator) on pneumatical tyres
- Abrasion resistant hose, 20 meters, diameter 32 mm
- Assembled nozzle, diameter 32 mm
- 1 spare nozzle tip
- 1 spare sealing plate
- Air hose, 20 meters
- Water hose, 20 meters



Available for order: hoses of various diameters, remote control, nozzles for different materials, explosion-proof electric motor, skids, rail platform, automatic lubrication system.

For the operation of the AC-1 machine required: the water supply pressure not less than 2 atm, the compressed air at least 4 m³/min, 3 kW electricity



TORNADO specialized in dry and wet shotcrete works and structures strengthening for more than 25 years. This unique work experience allows us to provide full-cycle services for shotcrete contractors. We strive to consider on-site conditions to get the best result for our Client.

- Wearing parts are always available for shipment
- Free onsite nozzleman machine operator training for wet and dry processes
- Special equipment editions on demand: alternative versions of the drives, remote control, extra consumables, types of material hoses and nozzles
- Full customer support

CONTACT

"Vyrobnichi Systemy Tornado" LTD Gudanova str., 18
Kharkiv, Ukraine

+38 057 782 25 12
+38 094 711 48 29

info@torkret.com.ua
shotcrete.torna-do.com

